

***FABRIJET***

***FT-1608 / FT-1908***

1.6m / 1.9m DYE SUBLIMATION



**FABRIJET**  
**FT-1608**

<b>Print Speed</b>	105 m <sup>2</sup> /hr	75 m <sup>2</sup> /hr	80 m <sup>2</sup> /hr	58 m <sup>2</sup> /hr
<b>Print Resolution</b>	720 x 360dpi 2 Pass	360 x 1,080dpi 3 Pass	540 x 720dpi 2 Pass	720 x 720dpi 4 Pass
<b>Max Print Width</b>	1,630 mm			
<b>Max Media Width</b>	1,650 mm			
<b>Print Mode</b>	Bi-Direction / Uni-Direction, Normal / Interleave			
<b>Printhead</b>	Panasonic printhead (8 heads)			
<b>Color</b>	4 Colors - Cyan, Magenta, Yellow, Black			
<b>Ink</b>	DGI original water based Dye Sublimation Ink			
<b>Interface</b>	TCP / IP , USB 3.0			
<b>Environmental Range</b>	Temperature : 22.5~27.5 °C		Humidity : 40~70%	
	Environment condition may affect on final printing quality.			
<b>Electricity Requirements</b>	Single Phase 220V (50/60Hz, AC) Main 5A, 3.3Kw Heater 10A			
<b>Optional equipment</b>	Heavy load take-up system - up to 400m(58g) media loadable / 6 Liter bulk ink tank system			

※ All specifications are subject to change without notice.

**FABRIJET**  
**FT-1908**

<b>Print Speed</b>	113 m <sup>2</sup> /hr	81 m <sup>2</sup> /hr	87 m <sup>2</sup> /hr	63 m <sup>2</sup> /hr
<b>Print Resolution</b>	720 x 360dpi 2 Pass	360 x 1,080dpi 3 Pass	540 x 720dpi 2 Pass	720 x 720dpi 4 Pass
<b>Max Print Width</b>	1,880 mm			
<b>Max Media Width</b>	1,900 mm			
<b>Print Mode</b>	Bi-Direction / Uni-Direction, Normal / Interleave			
<b>Printhead</b>	Panasonic printhead (8 heads)			
<b>Color</b>	4 Colors - Cyan, Magenta, Yellow, Black			
<b>Ink</b>	DGI original water based Dye Sublimation Ink			
<b>Interface</b>	TCP / IP , USB 3.0			
<b>Environmental Range</b>	Temperature : 22.5~27.5 °C		Humidity : 40~70%	
	Environment condition may affect on final printing quality.			
<b>Electricity Requirements</b>	Single Phase 220V (50/60Hz, AC) Main 5A, 3.3Kw Heater 10A			
<b>Optional equipment</b>	Heavy load take-up system - up to 400m(58g) media loadable / 6 Liter bulk ink tank system			

※ All specifications are subject to change without notice.

## Dimension for Installation

**FABRIJET**  
**FT-1608**

Printer	Uncrated				Crated			
	Length (mm)	Width (mm)	Height (mm)	Weight (kg)	Length (mm)	Width (mm)	Height (mm)	Weight (kg)
Printer	3,180	1,020	1,320	300	3,500	1,150	1,700	520

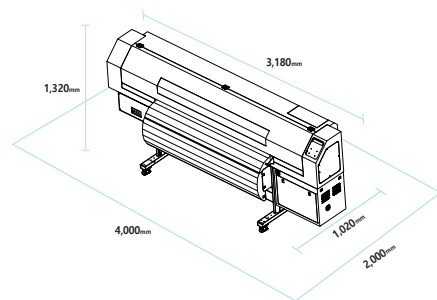

**FABRIJET**  
**FT-1908**

Printer	Uncrated				Crated			
	Length (mm)	Width (mm)	Height (mm)	Weight (kg)	Length (mm)	Width (mm)	Height (mm)	Weight (kg)
Printer	3,420	1,020	1,320	320	3,800	1,150	1,710	570

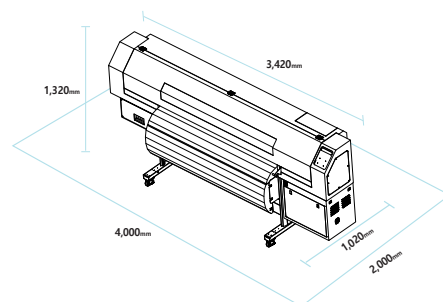

800-697-6523  
1110 Surret Drive, High Point, NC 27260  
www.axiomamerica.com



ISO 9001:14001 Certified